

# YAB

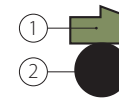

- ① **Type** Polytetrafluoroethylene PTFE + Bronze  
**Designation** SEALFLON + Bronze  
 ⇒ It can be provided with different fillers according to applications
- ② **Type** Nitril Rubber NBR  
**Designation** RUBSEAL 70  
**Hardness** 70 °ShA  
 ⇒ It can be provided with different materials according to working conditions

### FIELD OF APPLICATION

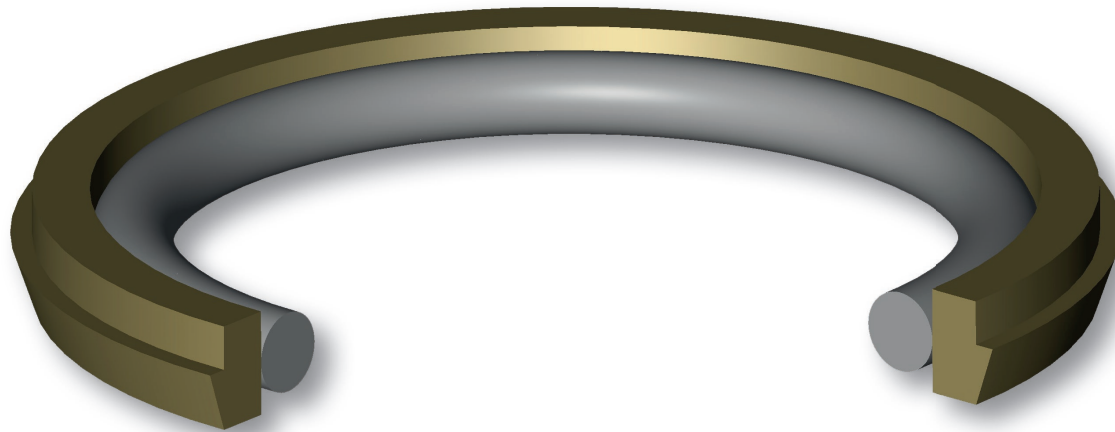
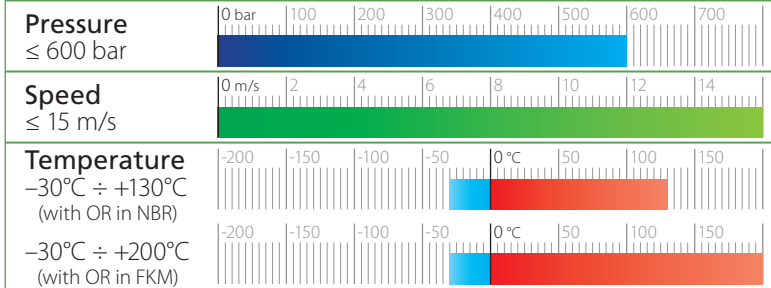

**Fluids** High compatibility with nearly all fluids (with the right choice of O-Ring material)

### SURFACE ROUGHNESS

<b>Dynamic surface</b>	Ra ≤ 0.3 μm	Rt ≤ 2.5 μm
<b>Static surface</b>	Ra ≤ 1.6 μm	Rt ≤ 6.3 μm

### GAP DIMENSION "g"

The largest gap dimension [mm] appearing in operation on the non-pressurised side:

L	100 bar	200 bar	400 bar
2.2	0.60	0.40	0.30
3.2	0.80	0.50	0.30
4.2	0.80	0.50	0.40
6.3	1.00	0.60	0.40
8.1	1.20	0.70	0.50
9.5	1.40	1.00	0.60
13.8	2.00	1.40	1.20
> 400 bar ⇒ $g_{max} = H8/f8$			

NB: for the Gap calculation, it is necessary to consider the elastic deformation of metal elements under pressure loads.

To avoid damaging the sealing lips during installation, housing must have rounded chamfers. Sharp edges and burrs within the installation area of the seal must be removed.

The above data are maximum values, they may be maintained for short periods and can not be used at the same time simultaneously.

The piston seal type Aston Seals YAB is composed of:

- A dynamic seal element which assures exceptional low friction and high speed performance, high compatibility with nearly all media due to the chemical resistance which exceeds that of all other thermoplastics and elastomers.
- A standard size O-Ring with low permanent deformation as energizing component on the static side
- Low static and dynamic friction
- High speed allowed
- No tendency of stick-slip
- Space-saving construction and simple groove

design

- High compatibility with nearly all fluids (with the right choice of O-Ring material)
- High resistance against extrusion
- High temperature resistance

# YAB

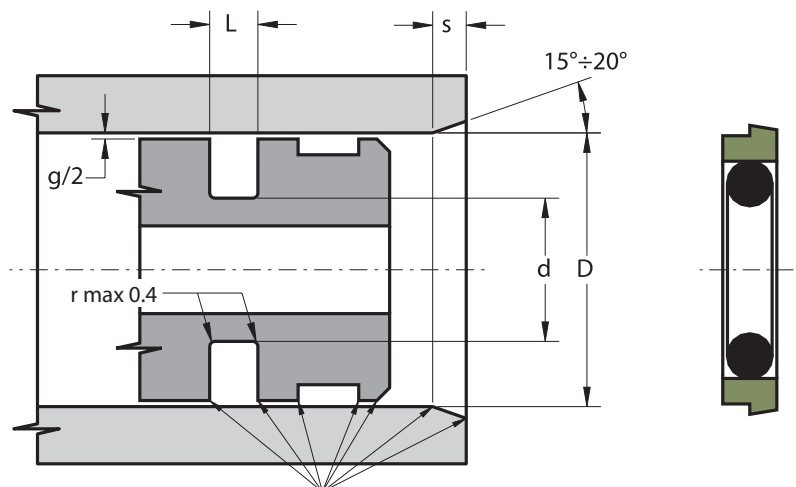

Rounded and burr free

Part.	D <sup>H9</sup>	d <sup>h9</sup>	L <sup>+0.2</sup>	S	OR
YAB 8 3.1 2.2	8	3.1	2.2	2.0	006
YAB 10 5.1 2.2	10	5.1	2.2	2.0	008
YAB 12 7.1 2.2	12	7.1	2.2	2.0	610
YAB 15 10.1 2.2	15	10.1	2.2	2.0	012
YAB 16 11.1 2.2	16	11.1	2.2	2.0	013
YAB 18 10.7 3.2	18	10.7	3.2	2.5	111
YAB 20 12.7 3.2	20	12.7	3.2	2.5	112
YAB 22 14.7 3.2	22	14.7	3.2	2.5	113
YAB 24 16.7 3.2	24	16.7	3.2	2.5	809
YAB 25 17.7 3.2	25	17.7	3.2	2.5	115
YAB 28 17.3 4.2	28	17.3	4.2	3.5	209
YAB 30 19.3 4.2	30	19.3	4.2	3.5	210
YAB 32 21.3 4.2	32	21.3	4.2	3.5	211
YAB 35 24.3 4.2	35	24.3	4.2	3.5	213
YAB 36 25.3 4.2	36	25.3	4.2	3.5	214
YAB 38 27.3 4.2	38	27.3	4.2	3.5	215
YAB 39 28.3 4.2	39	28.3	4.2	3.5	215
YAB 40 29.3 4.2	40	29.3	4.2	3.5	216
YAB 42 31.3 4.2	42	31.3	4.2	3.5	217
YAB 45 34.3 4.2	45	34.3	4.2	3.5	219
YAB 48 37.3 4.2	48	37.3	4.2	3.5	221
YAB 50 39.3 4.2	50	39.3	4.2	3.5	222
YAB 52 41.3 4.2	52	41.3	4.2	3.5	223
YAB 55 44.3 4.2	55	44.3	4.2	3.5	224

Part.	D <sup>H9</sup>	d <sup>h9</sup>	L <sup>+0.2</sup>	S	OR
YAB 57 46.3 4.2	57	46.3	4.2	3.5	828
YAB 60 44.9 6.3	60	44.9	6.3	5.0	327
YAB 63 47.9 6.3	63	47.9	6.3	5.0	328
YAB 64 48.9 6.3	64	48.9	6.3	5.0	328
YAB 65 49.9 6.3	65	49.9	6.3	5.0	328
YAB 70 54.9 6.3	70	54.9	6.3	5.0	330
YAB 75 59.9 6.3	75	59.9	6.3	5.0	332
YAB 80 64.9 6.3	80	64.9	6.3	5.0	333
YAB 85 69.9 6.3	85	69.9	6.3	5.0	335
YAB 89 73.9 6.3	89	73.9	6.3	5.0	336
YAB 90 74.9 6.3	90	74.9	6.3	5.0	336
YAB 95 79.9 6.3	95	79.9	6.3	5.0	337
YAB 100 84.9 6.3	100	84.9	6.3	5.0	340
YAB 105 89.9 6.3	105	89.9	6.3	5.0	341
YAB 110 94.9 6.3	110	94.9	6.3	5.0	343
YAB 115 99.9 6.3	115	99.9	6.3	5.0	344
YAB 120 104.9 6.3	120	104.9	6.3	5.0	346
YAB 125 109.9 6.3	125	109.9	6.3	5.0	347
YAB 130 114.9 6.3	130	114.9	6.3	5.0	349
YAB 132 116.9 6.3	132	116.9	6.3	5.0	349
YAB 133 117.9 6.3	133	117.9	6.3	5.0	350
YAB 135 119.9 6.3	135	119.9	6.3	5.0	351
YAB 140 124.9 6.3	140	124.9	6.3	5.0	352
YAB 145 129.9 6.3	145	129.9	6.3	5.0	353

Part.	D <sup>H9</sup>	d <sup>h9</sup>	L <sup>+0.2</sup>	S	OR
YAB 150 134.9 6.3	150	134.9	6.3	5.0	355
YAB 154 138.9 6.3	154	138.9	6.3	5.0	356
YAB 155 139.9 6.3	155	139.9	6.3	5.0	356
YAB 160 144.9 6.3	160	144.9	6.3	5.0	358
YAB 165 149.9 6.3	165	149.9	6.3	5.0	360
YAB 170 154.9 6.3	170	154.9	6.3	5.0	361
YAB 175 159.9 6.3	175	159.9	6.3	5.0	362
YAB 180 164.9 6.3	180	164.9	6.3	5.0	363
YAB 185 169.9 6.3	185	169.9	6.3	5.0	363
YAB 190 174.9 6.3	190	174.9	6.3	5.0	364
YAB 200 179.5 8.1	200	179.5	8.1	6.5	441
YAB 210 189.5 8.1	210	189.5	8.1	6.5	882
YAB 220 199.5 8.1	220	199.5	8.1	6.5	444
YAB 230 209.5 8.1	230	209.5	8.1	6.5	445
YAB 240 219.5 8.1	240	219.5	8.1	6.5	446
YAB 250 229.5 8.1	250	229.5	8.1	6.5	447
YAB 260 236 8.1	260	236.0	8.1	6.5	447
YAB 270 246 8.1	270	246.0	8.1	6.5	448
YAB 280 256 8.1	280	256.0	8.1	6.5	449
YAB 290 266 8.1	290	266.0	8.1	6.5	449
YAB 300 276 8.1	300	276.0	8.1	6.5	451
YAB 310 286 8.1	310	286.0	8.1	6.5	451
YAB 320 296 8.1	320	296.0	8.1	6.5	452
YAB 330 306 8.1	330	306.0	8.1	6.5	453

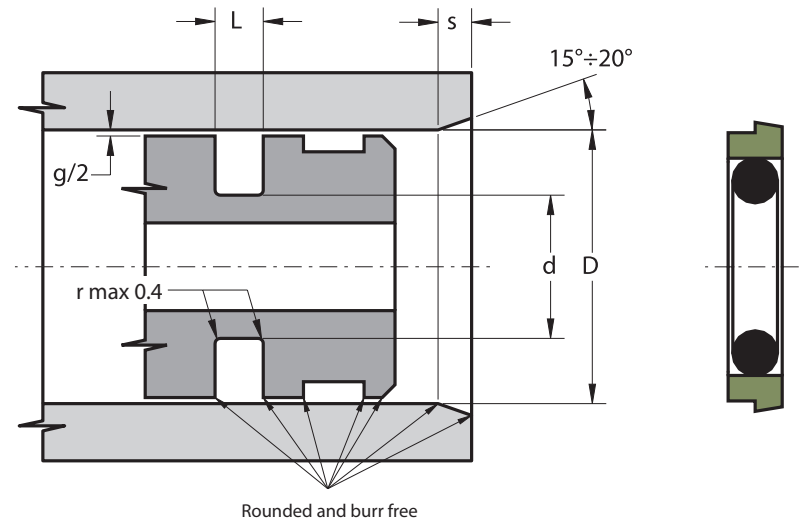

Part.	D <sup>H9</sup>	d <sup>h9</sup>	L <sup>+0.2</sup>	S	OR
<b>YAB 340 316 8.1</b>	340	316.0	8.1	6.5	453
<b>YAB 350 326 8.1</b>	350	326.0	8.1	6.5	454
<b>YAB 360 336 8.1</b>	360	336.0	8.1	6.5	455
<b>YAB 370 346 8.1</b>	370	346.0	8.1	6.5	456
<b>YAB 380 356 8.1</b>	380	356.0	8.1	6.5	457
<b>YAB 390 366 8.1</b>	390	366.0	8.1	6.5	457
<b>YAB 400 376 8.1</b>	400	376.0	8.1	6.5	458
<b>YAB 410 386 8.1</b>	410	386.0	8.1	6.5	459
<b>YAB 420 396 8.1</b>	420	396.0	8.1	6.5	460
<b>YAB 430 406 8.1</b>	430	406.0	8.1	6.5	461
<b>YAB 440 416 8.1</b>	440	416.0	8.1	6.5	461
<b>YAB 450 426 8.1</b>	450	426.0	8.1	6.5	462
<b>YAB 460 436 8.1</b>	460	436.0	8.1	6.5	463
<b>YAB 470 446 8.1</b>	470	446.0	8.1	6.5	464
<b>YAB 480 456 8.1</b>	480	456.0	8.1	6.5	464
<b>YAB 490 466 8.1</b>	490	466.0	8.1	6.5	465
<b>YAB 500 476 8.1</b>	500	476.0	8.1	6.5	466

Other sizes not present in the above table can be provided in according to the following scheme:

D			d	L	S	S. OR
Light series	Standard series	Heavy series				
17 ÷ 26.9	<b>8 ÷ 16.9</b>		D - 4.9	2.2	2.0	1.78
27 ÷ 59.9	<b>17 ÷ 26.9</b>		D - 7.3	3.2	2.5	2.62
60 ÷ 199.9	<b>27 ÷ 59.9</b>	17 ÷ 26.9	D - 10.7	4.2	3.5	3.53
200 ÷ 255.9	<b>60 ÷ 199.9</b>	27 ÷ 59.9	D - 15.1	6.3	5.0	5.34
256 ÷ 669.9	<b>200 ÷ 255.9</b>	60 ÷ 199.9	D - 20.5	8.1	6.5	6.99
670 ÷ 999.9	<b>256 ÷ 669.9</b>	200 ÷ 255.9	D - 24.0	8.1	6.5	6.99
	<b>670 ÷ 999.9</b>	256 ÷ 669.9	D - 27.3	9.5	7.5	8.40
	<b>&gt; 1000</b>		D - 38.0	13.8	10.0	12.0