

# SAP



SAP

The function of the Aston Seals SAP wiper ring is to prevent introduction of dust, dirt, foreign matter and heavily deposited ice and mud into the system.

This is achieved by a special wiper lip which produces a very effective cleaning action, prevents the development of scores, protects the guiding parts and extends the service life of the axial moving rod seals.

An external sealing lip on the outside diameter contacts the housing in order to prevent moisture entering the groove.

The internal ribs give stability, back pumping ability and prevent sticking of the wiper in the groove.

The material used to produce this wiper is a spe-

cial polyester resin that ensures excellent properties in case of heavy applications, an increased wear-resistance and an extended service life.

- External sealing lip for a real housing protection
- Suitable for heavy applications
- Back pumping ability
- Extended service life
- Low cost solution
- Excellent wear-resistance
- Space-saving construction
- Easy installation without expensive auxiliaries

## MATERIAL



**Type**  
Thermoplastic polyester resin

**Designation**  
SEALITE 55

**Hardness**  
55 °ShD

## FIELD OF APPLICATION

**Speed**  
≤ 4 m/s



**Temperature**  
-40°C ÷ +100°C

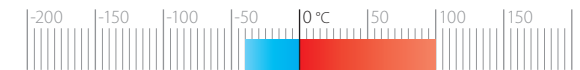

**Fluids**

Hydraulic oils (mineral oil based)  
For other fluids contact our technical department

## SURFACE ROUGHNESS

**Dynamic surface**  
**Static surface**

Suitable for rod seal system  
Ra ≤ 1.6 μm      Rt ≤ 6.3 μm

## LEAD-IN CHAMFERS

d	Smin
less 100	5 mm
100÷200	7 mm
over 200	10 mm

Any pressure loads on the back of the rings should be avoided. Sharp edges and burrs within the installation area must be removed. The above data are maximum values, they may be maintained for short periods and can not be used at the same time simultaneously.

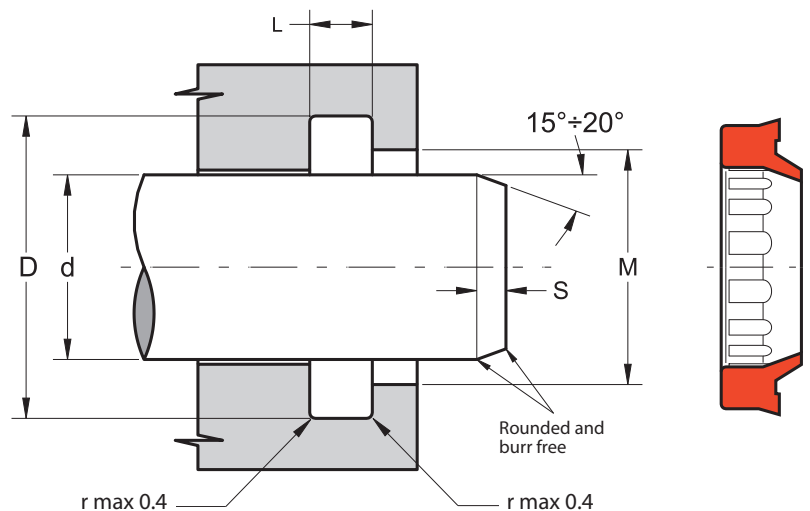

Part.	d <sup>f7</sup>	D <sup>H10</sup>	L <sup>+0.2</sup>	M <sup>+0.2</sup>
SAP 20 28 5	20	28.0	5.0	25.5
SAP 22 30 5	22	30.0	5.0	27.5
SAP 25 33 5	25	33.0	5.0	30.5
SAP 28 36 5	28	36.0	5.0	33.5
SAP 30 38 5	30	38.0	5.0	35.5
SAP 32 40 5	32	40.0	5.0	37.5
SAP 35 43 5	35	43.0	5.0	40.5
SAP 36 44 5	36	44.0	5.0	41.5
SAP 40 48 5	40	48.0	5.0	45.5
SAP 45 53 5	45	53.0	5.0	50.5
SAP 45 55.6 5.3	45	55.6	5.3	48.0
SAP 50 58 5	50	58.0	5.0	55.5
SAP 50 60.6 5.3	50	60.6	5.3	53.0
SAP 55 63.6 5.3	55	63.6	5.3	58.0
SAP 55 65 5.3	55	65.0	5.3	61.0
SAP 55 65 6.3	55	65.0	6.3	61.0
SAP 56 66 6.3	56	66.0	6.3	63.0
SAP 60 70 5.3	60	70.0	5.3	66.0
SAP 60 70 6.3	60	70.0	6.3	67.0
SAP 63 73 6.3	63	73.0	6.3	70.0
SAP 63 73.6 5.3	63	73.6	5.3	66.0
SAP 65 75 5.3	65	75.0	5.3	68.0
SAP 70 78 5	70	78.0	5.0	75.5

Part.	d <sup>f7</sup>	D <sup>H10</sup>	L <sup>+0.2</sup>	M <sup>+0.2</sup>
SAP 70 80 6.3	70	80.0	6.3	77.0
SAP 70 80.6 5.3	70	80.6	5.3	73.0
SAP 70 82.2 7.2	70	82.2	7.2	76.0
SAP 75 83 5	75	83.0	5.0	80.5
SAP 75 85 6.3	75	85.0	6.3	82.0
SAP 80 90 6.3	80	90.0	6.3	87.0
SAP 90 100 6.3	90	100.0	6.3	97.0
SAP 90 102.2 7.1	90	102.2	7.1	96.0
SAP 95 107.2 7.2	95	107.2	7.2	101.0
SAP 100 110.6 5.3	100	110.6	5.3	104.0
SAP 100 112.2 7.1	100	112.2	7.1	106.0
SAP 100 115 9.5	100	115.0	9.5	110.0
SAP 105 117.2 7.1	105	117.2	7.1	111.0
SAP 110 122.2 7.1	110	122.2	7.1	116.0
SAP 130 142.2 7.2	130	142.2	7.2	136.0
SAP 135 150 9.5	135	150.0	9.5	145.0

#### Inch sizes

SAP 1250 1625 0187	31.75	41.28	4.75	37.97
SAP 1500 1875 0187	38.10	47.63	4.75	44.32
SAP 1750 2125 0187	44.45	53.98	4.75	50.67
SAP 2000 2500 0250	50.80	63.50	6.35	59.10