

SAC

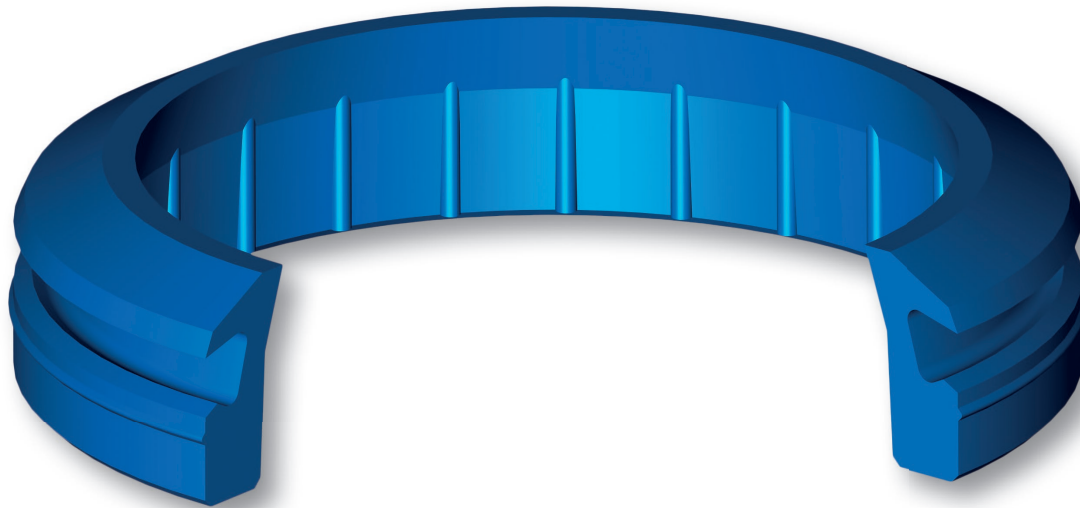

SAC

MATERIAL

	Type Polyurethane	Designation SEALPUR 93	Hardness 93 °ShA
---	-----------------------------	----------------------------------	----------------------------

FIELD OF APPLICATION

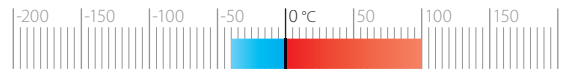
Speed ≤ 0.8 m/s	
Temperature -40°C ÷ +100°C	
Fluids	Hydraulic oils (mineral oil based) For other fluids contact our technical department

SURFACE ROUGHNESS

Dynamic surface	Suitable for rod seal system
Static surface	Ra ≤ 1.6 µm Rt ≤ 6.3 µm

LEAD-IN CHAMFERS

d	Smin
less 100	5 mm
100÷200	7 mm
over 200	10 mm

Any pressure loads on the back of the rings should be avoided.
Sharp edges and burrs within the installation area must be removed.
The above data are maximum values, they may be maintained for short periods and can not be used at the same time simultaneously.

The function of the Aston Seals SAC wiper ring is to prevent introduction of dust, dirt and foreign matter into the system, to protect the guiding parts and to extend the service life of the axial moving rod seals.

This is achieved by:

- a special wiper lip which produces a very effective cleaning action and prevents the development of scores.
- an external flap which covers the gland housing, preventing the slurry retention and the ingress of contamination around the outside, as happens in traditional wipers.
- An additional external sealing lip on the outside diameter as a further protection against moisture entering the groove.

The internal ribs give stability, prevent twisting and sticking of the wiper in the groove as well as release back-pressure between the rod seal and the wiper.

The material used to produce this wiper is a polyurethane compound that ensures excellent properties in case of dry run, an increased wear-resistance and an extended service life due to good resistance against ozone and radiation caused by weather conditions.

- External flap for a absolute protection against moisture entering the groove
- Suitable for hard and heavy environments
- Particularly suitable for vertical cylinders
- Extended service life
- Back pumping ability
- Excellent wear-resistance
- Space-saving construction
- Easy installation without expensive auxiliaries

SAC

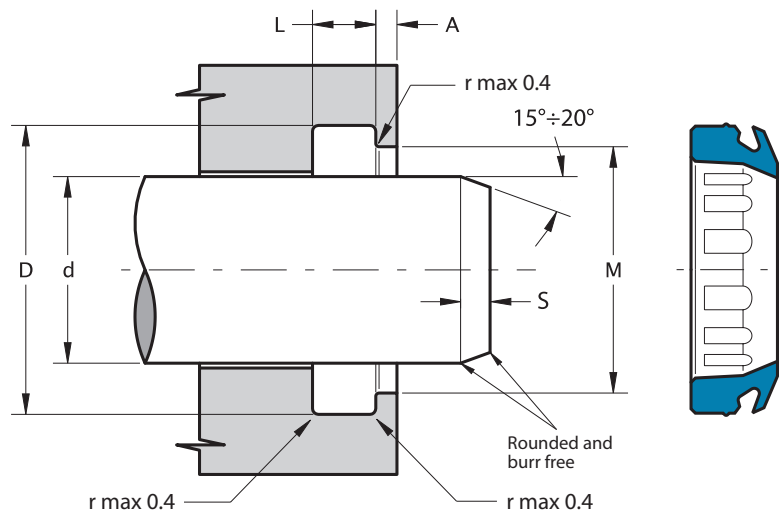

Part.	d ^{f7}	D ^{H10}	L ^{+0.2}	M ^{H11}	A ^{+0.1}
SAC 35 45 6.3	35	45.0	6.3	42.0	1.5
SAC 36 44 5	36	44.0	5.0	41.5	1.5
SAC 40 48 5	40	48.0	5.0	45.5	1.5
SAC 45 53 5	45	53.0	5.0	50.5	1.5
SAC 50 58 5	50	58.0	5.0	55.5	1.5
SAC 56 66 6.3	56	66.0	6.3	63.0	1.5
SAC 60 70 6.3	60	70.0	6.3	67.0	1.5
SAC 63 73 6.3	63	73.0	6.3	70.0	1.5
SAC 70 82.6 8	70	82.6	8.0	78.4	2.0
SAC 80 90 6.3	80	90.0	6.3	87.0	1.5
SAC 90 102.2 7.1	90	102.2	7.1	96.0	2.8