

OP



MATERIAL



Type	Designation	Hardness
Polyurethane	SEALPUR 93	93 °ShA

FIELD OF APPLICATION

Pressure	See table below
Speed	Depending of working condition. It is preferable as static seal
Temperature	-30°C ÷ +80°C
Fluids	Hydraulic oils (mineral oil based) For other fluids contact our technical department

GAP DIMENSION "g"

In order to avoid extrusion, the maximum pressure allowed depends on the fitting gap:

1.20 mm	50 bar	0.25 mm	300 bar
0.80 mm	100 bar	0.17 mm	400 bar
0.40 mm	200 bar	0.10 mm	500 bar

NB: for the Gap calculation, it is necessary to consider the elastic deformation of metal elements under pressure loads.

SURFACE ROUGHNESS

Housing surface	Ra ≤ 0.8 µm	Rt ≤ 4.8 µm
------------------------	-------------	-------------

To avoid damaging the sealing lips during installation, housing must have rounded chamfers. Sharp edges and burrs within the installation area of the seal must be removed.

The above data are maximum values, they may be maintained for short periods and can not be used at the same time simultaneously.

The Aston Seals OP seal has been developed to be used as a valid alternative of the O-Ring for heavy duty applications to avoid the extrusion and damage of it that normally occurs in the presence of large gaps or high pressure.

It is a static (preferable) seal energized by pressure and can work as a single or double acting sealing element. The radial sealing forces, which guarantee good sealing performance, increase when the pressure rises.

Thanks to its elasticity, it can be installed very easily in a short time and without any auxiliaries.

The material used to produce this seal is

a polyurethane compound that ensures excellent properties on wear-resistance, extended service life and resistance against extrusion

- High resistance against extrusion
- Resistance to twisting
- Single and double acting
- Simple groove design
- Stability at pulsating pressure
- Extended service life
- Easy installation without expensive auxiliaries

OP

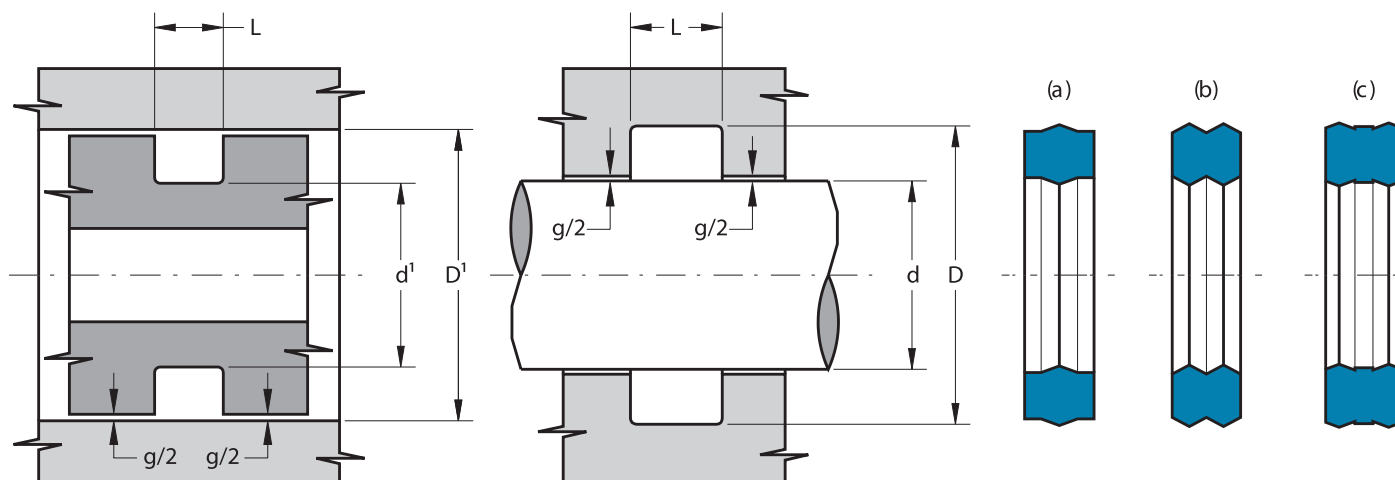

Part.	d ^{f7}	D ^{H9}	d ^{1h9}	D ^{1H8}	L ^{+0.2}	Tp.
OP 008	4.5	7.6	4.9	8	2.5	(a)
OP 009	5	8.1	5.9	9	2.5	(a)
OP 012	9	12.1	9.9	13	2.5	(a)
OP 013	11	14.1	10.9	14	2.5	(a)
OP 014	13	16.1	12.9	16	2.5	(a)
OP 014/A	-	-	13.07	15.93	3.5	(b)
OP 015	14	17.1	14.9	18	2.5	(a)
OP 015/A	-	-	14.67	17.53	3.5	(b)
OP 016	16	19.1	15.9	19	2.5	(a)
OP 016/A	-	-	16.25	19.12	3.5	(b)
OP 020/A	-	-	23.1	26	3.5	(b)
OP 023	27	30.1	26.9	30	2.5	(a)
OP 031	44	47.1	44.9	48	2.5	(a)
OP 034	54	57.1	54.9	58	2.5	(a)
OP 109	8	12.5	8.5	13	3.5	(b)
OP 113	14	18.5	14.5	19	3.5	(b)
OP 115	17	21.5	17.5	22	3.5	(b)
OP 116/A	19	23.6	-	-	5.5	(b)
OP 117	20	24.5	20.5	25	3.5	(b)
OP 118/813	22	26.5	22.5	27	3.5	(b)
OP 119	24	28.5	24.5	29	3.5	(b)
OP 120	25	29.5	25.5	30	3.5	(b)
OP 121	28	32.5	27.5	32	3.5	(b)
OP 123	30	34.5	30.5	35	3.5	(b)

Part.	d ^{f7}	D ^{H9}	d ^{1h9}	D ^{1H8}	L ^{+0.2}	Tp.
OP 126	35	39.5	35.5	40	3.5	(b)
OP 129	40	44.5	40.5	45	3.5	(b)
OP 130	41	45.5	41.5	46	3.5	(b)
OP 132	44	48.5	44.5	49	3.5	(b)
OP 133	46	50.5	46.5	51	3.5	(b)
OP 138	54	58.5	54.5	59	3.5	(b)
OP 138/A	54	58.5	54.5	59	5.0	(b)
OP 140/A	57	61.5	57.5	62	5.0	(b)
OP 142/A	60	64.5	60.5	65	5.0	(b)
OP 147	68	72.5	68.5	73	3.5	(b)
OP 153	89	93.5	89.5	94	3.5	(b)
OP 156	108	112.5	108.5	113	3.5	(b)
OP 209	17	23.2	17.8	24	4.5	(b)
OP 210	19	25.2	19.8	26	4.5	(b)
OP 211	20	26.2	21.8	28	4.5	(b)
OP 216	28	34.2	28.8	35	4.5	(b)
OP 216/A	28	34.3	-	-	6.5	(b)
OP 217	30	36.2	30.8	37	4.5	(b)
OP 217/A	30	36.3	-	-	6.5	(b)
OP 218	31	37.2	31.8	38	4.5	(b)
OP 219	33	39.2	33.8	40	4.5	(b)
OP 220	35	41.2	35.8	42	4.5	(b)
OP 225/829	48	54.2	47.8	54	4.5	(b)
OP 227/833	54	60.2	54.8	61	4.5	(b)

Part.	d ^{f7}	D ^{H9}	d ^{1h9}	D ^{1H8}	L ^{+0.2}	Tp.
OP 230	64	70.2	63.8	70	4.5	(b)
OP 233	73	79.2	73.8	80	4.5	(b)
OP 233/845/A	73	79.2	73.8	80	6.5	(c)
OP 234	76	82.2	76.8	83	4.5	(b)
OP 235	79	85.2	79.8	86	4.5	(b)
OP 236	82	88.2	82.8	89	4.5	(b)
OP 238	89	95.2	88.8	95	4.5	(b)
OP 239	92	98.2	92.8	99	4.5	(b)
OP 240/A	95	101.2	95.8	102	6.5	(b)
OP 242/A	-	-	101.5	107.8	6.1	(c)
OP 247	117	123.2	117.8	124	4.5	(b)
OP 256	146	152.2	145.8	152	4.5	(b)
OP 326/A	41	50.4	42.6	52	9.5	(c)
OP 335/A	69	78.4	70.6	80	9.5	(c)
OP 337/A	76	85.4	76.6	86	9.5	(c)
OP 340/A	85	94.4	85.6	95	9.5	(c)
OP 342/A	92	101.4	92.6	102	9.5	(c)
OP 346/A	104	113.4	105.6	115	9.5	(c)
OP 349/A	114	123.4	115.6	125	9.5	(c)
OP 350/A	117	126.4	118.6	128	9.5	(c)
OP 430	130	142.2	130.8	143	9.5	(c)
OP 614	12	16.8	-	-	3.5	(b)
OP 616	15	19.5	15.5	20	3.5	(b)
OP 617	18	22.8	-	-	3.5	(b)

OP

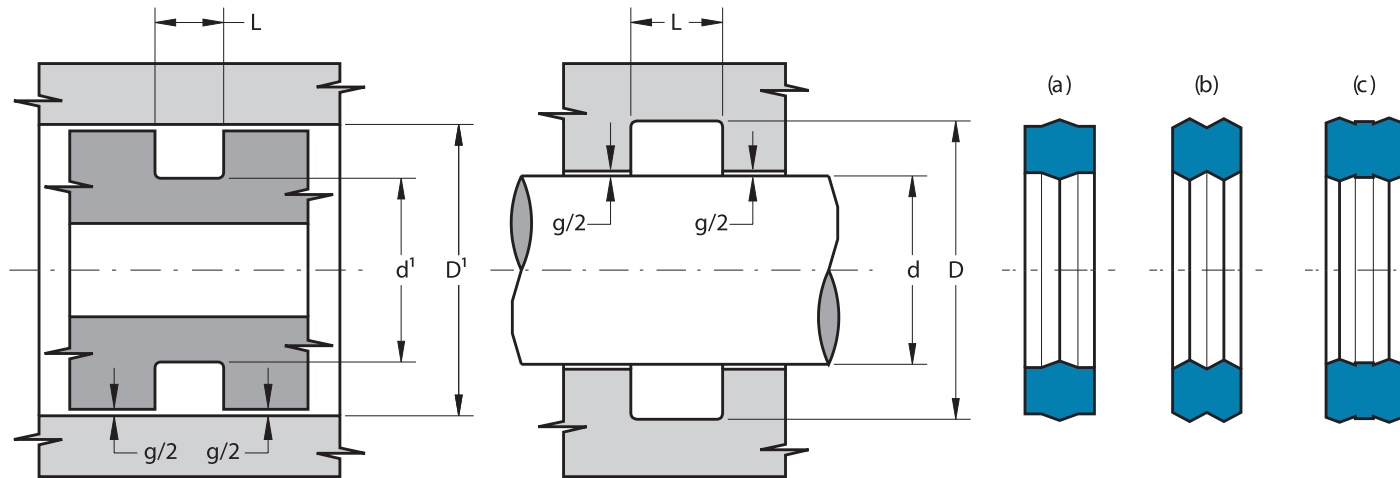

Part.	d ^{f7}	D ^{H9}	d ^{1 h9}	D ^{1 H8}	L ^{+0.2}	Tp.
OP 620	80	89.4	80.6	90	7.0	(c)
OP 621	90	99.4	90.6	100	7.0	(c)
OP 621/A	90	99.4	90.6	100	9.5	(c)
OP 623/A	110	119.4	110.6	120	9.5	(c)
OP 674	210	222.2	209.8	222	9.5	(c)
OP 806	11	14.1	11.9	15	2.5	(a)
OP 806/A	-	-	12.1	15	3.5	(b)
OP 812	21	25.5	21.5	26	3.5	(b)
OP 824	40	46.2	39.8	46	4.5	(b)
OP 826	43	49.2	43.8	50	4.5	(b)
OP 832	52	58.2	53.8	60	4.5	(b)
OP 834	56	62.2	55.8	62	4.5	(b)
OP 835	57	63.2	57.8	64	4.5	(b)
OP 836	59	65.2	58.8	65	4.5	(b)
OP 836/A	59	65.2	58.8	65	6.5	(c)
OP 839	64	70.2	63.8	70	4.5	(b)
OP 842	68	74.2	68.8	75	4.5	(b)
OP 845	73	79.2	73.8	80	4.5	(b)

OP

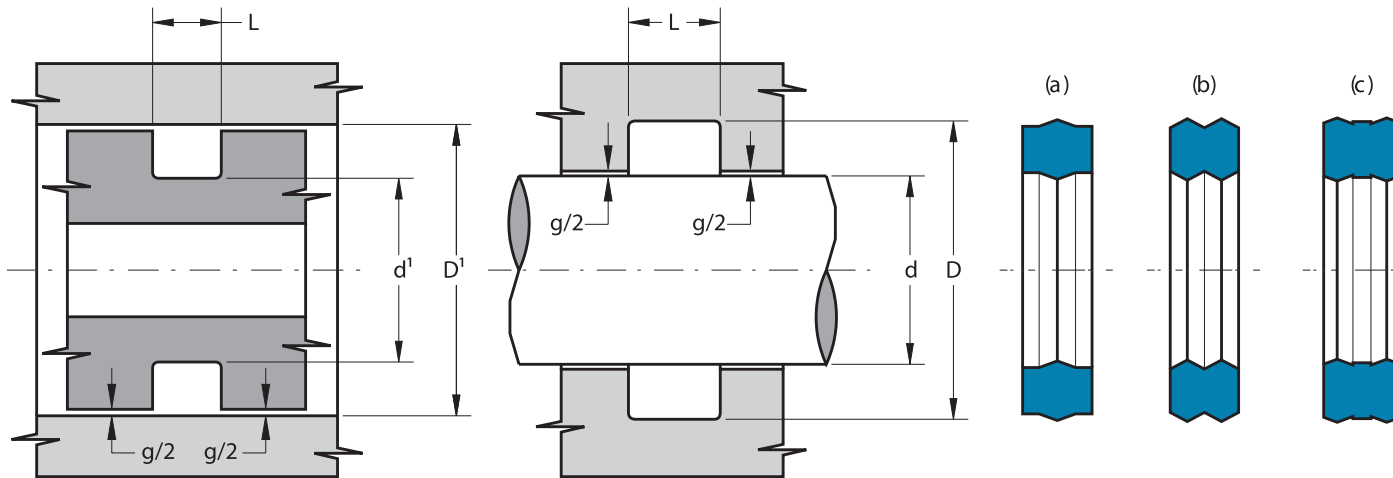

Part.	d ^{f7}	D ^{H8}	L ^{+0.2}	Tp.
-------	-----------------	-----------------	-------------------	-----

- Metric range -

OP 9 11.5 2.1	9	11.5	2.5	(a)
OP 9.25 12 2.5	9.25	12	3.0	(a)
OP 10 14.4 3	10	14.4	3.5	(b)
OP 10.6 13.4 2.1	10.6	13.4	2.5	(a)
OP 12 16.6 2.6	12	16.6	3.1	(b)
OP 12 18 6	12	18	7.0	(b)
OP 12.8 17.15 2.64	12.8	17.15	3.14	(b)
OP 14 30 12	14	30	13.0	(b)
OP 15.85 20 4	15.85	20	4.5	(b)
OP 16 20 3	16	20	3.5	(b)
OP 16 30 7.5	16	30	8.5	(b)
OP 16 30 10	16	30	11.0	(b)
OP 16 35 15	16	35	16.0	(b)
OP 17 22 4	17	22	4.5	(b)
OP 18.4 21 2	18.4	21	2.5	(a)
OP 18.7 21.5 3	18.7	21.5	3.5	(b)
OP 19.9 22.5 3	19.9	22.5	3.5	(b)
OP 21.3 24 3	21.3	24	3.5	(b)
OP 21.3 24 4.5	21.3	24	5.0	(b)
OP 23 28 4.5	23	28	5.0	(b)
OP 25.4 30 4.9	25.4	30	5.4	(b)

Part.	d ^{f7}	D ^{H8}	L ^{+0.2}	Tp.
-------	-----------------	-----------------	-------------------	-----

OP 26.6 35 5.5	26.6	35	6.5	(b)
OP 27.5 33.6 4	27.5	33.6	4.5	(b)
OP 28.4 32.6 3	28.4	32.6	3.6	(b)
OP 29 34 4	29	34	4.5	(b)
OP 30.4 35 4.5	30.4	35	5.0	(b)
OP 32.8 38 4	32.8	38	4.5	(b)
OP 33.2 36 3.2	33.2	36	3.6	(b)
OP 33.2 36 4.25	33.2	36	4.75	(b)
OP 34.6 40.55 5	34.6	40.55	5.5	(b)
OP 34.6 40.7 4	34.6	40.7	4.5	(b)
OP 35.1 40.6 4	35.1	40.6	4.6	(b)
OP 35.1 41 5.5	35.1	41	6.5	(b)
OP 35.2 38 4.25	35.2	38	4.75	(b)
OP 35.2 40 4.9	35.2	40	5.4	(b)
OP 35.4 40 3.4	35.4	40	3.9	(b)
OP 39 45.2 4	39	45.2	4.5	(b)
OP 40 45 4.9	40	45	5.4	(b)
OP 42.6 48 5.7	42.6	48	6.7	(b)
OP 44.6 50 5.2	44.6	50	6.2	(b)
OP 45.4 50 3.4	45.4	50	3.9	(b)
OP 45.4 50 4.9	45.4	50	5.4	(b)
OP 45.5 50.5 3.5	45.5	50.5	4.0	(b)
OP 47.5 52 3	47.5	52	3.5	(b)
OP 50.4 55 3.4	50.4	55	3.9	(b)

Part.	d ^{f7}	D ^{H8}	L ^{+0.2}	Tp.
-------	-----------------	-----------------	-------------------	-----

OP 50.4 55 4.9	50.4	55	5.4	(b)
OP 50.5 55 3	50.5	55	3.5	(b)
OP 52.2 57 3.5	52.2	57	4.0	(b)
OP 53.8 63 8.7	53.8	63	9.7	(c)
OP 56 61 4	56	61	4.5	(b)
OP 57.6 63 5.2	57.6	63	6.2	(b)
OP 58.4 63 4.9	58.4	63	5.4	(b)
OP 60 66 5.5	60	66	6.5	(b)
OP 60.2 64 2.8	60.2	64	3.2	(b)
OP 60.5 65 3	60.5	65	3.5	(b)
OP 61.4 66 3.5	61.4	66	4.0	(b)
OP 61.5 66 3	61.5	66	3.5	(b)
OP 64.3 70 5.7	64.3	70	6.7	(b)
OP 67 73.2 4	67	73.2	4.5	(b)
OP 69.4 75 4.8	69.4	75	5.3	(b)
OP 70 75.6 5.2	70	75.6	6.2	(b)
OP 73 78 4	73	78	4.5	(b)
OP 73 81 5.6	73	81	6.6	(b)
OP 73.6 80 5.4	73.6	80	6.4	(b)
OP 73.8 80 5.9	73.8	80	6.9	(c)
OP 74.4 80 4.8	74.4	80	5.3	(b)
OP 74.5 80 4	74.5	80	4.5	(b)
OP 78.5 83 3	78.5	83	3.5	(b)
OP 78.9 85.2 5.5	78.9	85.2	6.0	(b)

OP

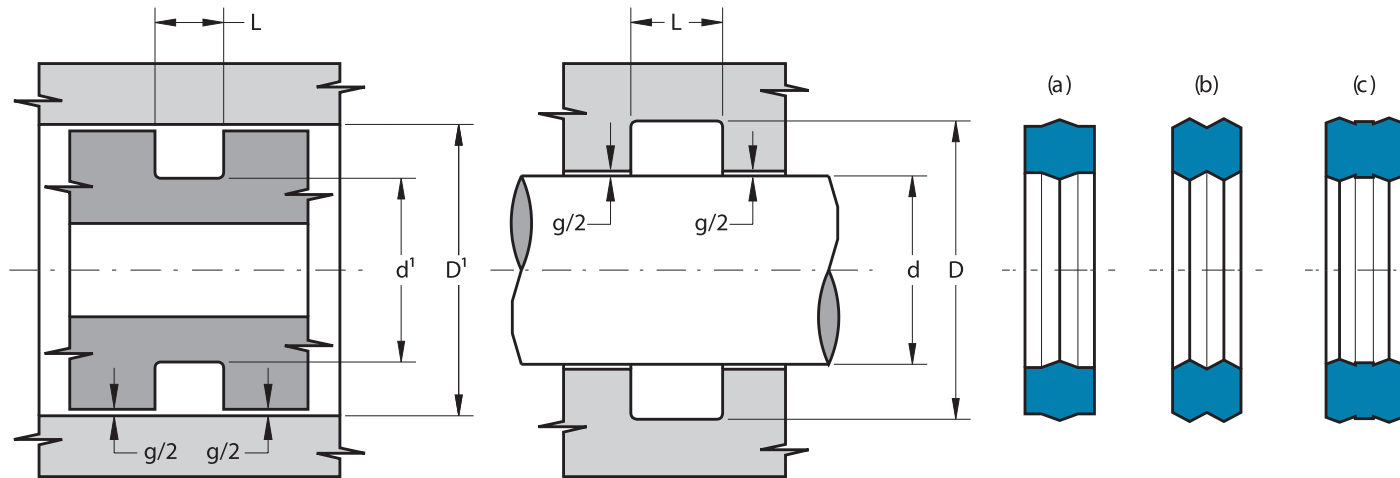

Part.	d ^{f7}	D ^{H8}	L ^{+0.2}	Tp.
OP 79.3 85 5.7	79.3	85	6.7	(b)
OP 80.4 85 4.9	80.4	85	5.4	(b)
OP 80.6 90 8	80.6	90	9.0	(c)
OP 83 90 5.5	83	90	6.5	(b)
OP 84.3 90 5.7	84.3	90	6.7	(b)
OP 85.4 90 4.9	85.4	90	5.4	(b)
OP 85.5 90.5 4.5	85.5	90.5	5.0	(b)
OP 88 96 5.6	88	96	6.6	(b)
OP 90.8 100 8.7	90.8	100	9.7	(c)
OP 91.4 100 8	91.4	100	9.0	(c)
OP 93.8 100 5.9	93.8	100	6.9	(c)
OP 95.4 100 4.9	95.4	100	5.4	(b)
OP 96 101 4.5	96	101	5.0	(b)
OP 101 106 4.5	101	106	5.0	(b)
OP 101.4 110 8	101.4	110	9.0	(c)
OP 101.7 111 7.5	101.7	111	8.5	(c)
OP 103 111 5.6	103	111	6.6	(b)
OP 105 111 5.5	105	111	6.5	(b)
OP 106.2 112 5.1	106.2	112	6.0	(c)

Part.	d ^{f7}	D ^{H8}	L ^{+0.2}	Tp.
OP 106.7 116 7.5	106.7	116	8.5	(c)
OP 107.2 113 5.1	107.2	113	6.0	(c)
OP 110 116 5.5	110	116	6.5	(b)
OP 113 120 5	113	120	6.0	(b)
OP 114.2 120 5	114.2	120	6.0	(b)
OP 115.5 120.25 3.7	115.5	120.25	4.2	(b)
OP 116.4 125 8	116.4	125	9.0	(c)
OP 117 122.8 5.1	117	122.8	6.0	(b)
OP 118 126 5.6	118	126	6.6	(b)
OP 125.2 131 5.1	125.2	131	6.0	(c)
OP 129.2 135 5.1	129.2	135	6.0	(c)
OP 130 138 6	130	138	7.0	(b)
OP 131.6 140 7.6	131.6	140	8.6	(c)
OP 132.8 145 8.5	132.8	145	9.5	(c)
OP 134 140.3 5	134	140.3	6.0	(b)
OP 140.2 146 4	140.2	146	4.5	(b)
OP 143 152 8.1	143	152	9.1	(c)
OP 144 155.5 9.5	144	155.5	10.5	(c)
OP 145 151 5	145	151	6.0	(c)

Part.	d ^{f7}	D ^{H8}	L ^{+0.2}	Tp.
OP 148.4 160 11.3	148.4	160	12.3	(c)
OP 155.1 163.5 7.5	155.1	163.5	8.5	(b)
OP 160.2 166 4	160.2	166	4.5	(b)
OP 165 171 5	165	171	6.0	(c)
OP 165.8 175 8.8	165.8	175	9.8	(b)
OP 166.4 175 8.1	166.4	175	9.1	(c)
OP 168 179.5 9.5	168	179.5	10.5	(c)
OP 185 191 5	185	191	6.0	(c)
OP 185.8 195 8.9	185.8	195	9.9	(b)
OP 188.4 200 11.3	188.4	200	12.3	(c)
OP 192 198 5	192	198	6.0	(c)
OP 196.4 205 8	196.4	205	9.0	(b)
OP 207 213 5	207	213	6.0	(c)
OP 217.4 229 11	217.4	229	12.0	(c)
OP 231 244 7.5	231	244	8.5	(b)
OP 233.5 240.5 8	233.5	240.5	9.0	(c)
OP 248 254 5	248	254	6.0	(b)
OP 262 272 8.5	262	272	9.5	(c)
OP 293 303 8.5	293	303	9.5	(c)