

GRF

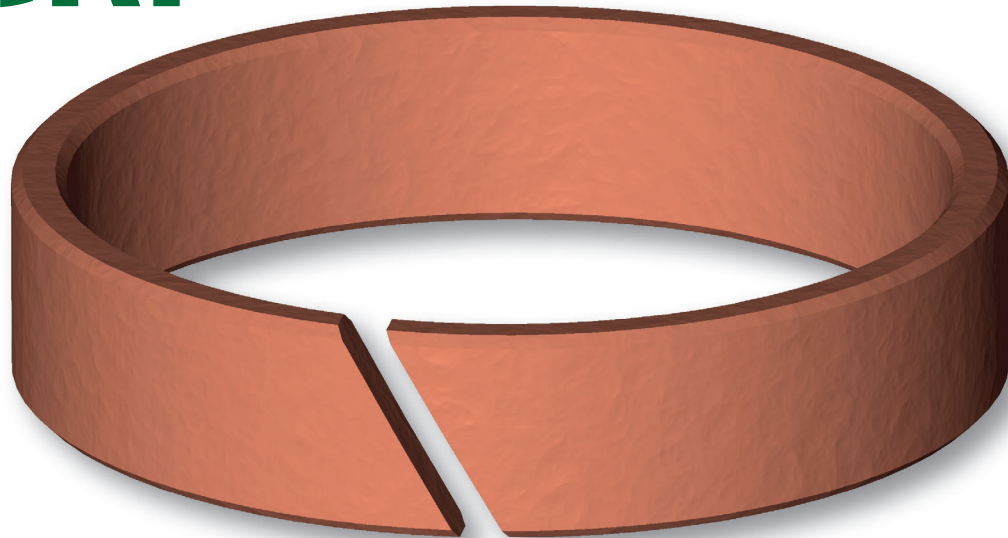

MATERIAL



Type
Phenolic resin in cotton fabric

Designation
PHENOLITE

FIELD OF APPLICATION

Speed
≤ 1 m/s

Temperature
-40°C ÷ +130°C

Fluids
Hydraulic oils (mineral oil based)
For other fluids contact our technical department

SURFACE ROUGHNESS

Dynamic surface	Ra ≤ 0.3 μm	Rt ≤ 2.5 μm
Static surface	Ra ≤ 2 μm	Rt ≤ 10 μm

CHOICE OF GUIDE RING WIDTH

A rough estimate of guide width can be calculated with the following formula:

$$h_{mm} \geq \frac{F_N \times k}{p_{N/mm^2} \times d_{mm}}$$

where

- h_{mm} • Guide ring width in mm
 - F_N • Radial load in N
 - k • Safety factor (generally 2)
 - d_{mm} • Rod diameter in mm
 - p_{N/mm^2} • Surface pressure N/mm²
- 100 a 20 °C
75 a 70 °C
50 a 120 °C

Before assembly good cleanliness and lubrication are recommended.

The above data are maximum values, they may be maintained for short periods and can not be used at the same time simultaneously.

The Aston Seals GRF type guide rings have been developed to substitute traditional bronze guides in hydraulic cylinders. They guide the rod or the piston and prevent metallic contact with the cylinder when radial forces act perpendicular to the direction of movement.

Since GRF guide rings are machined from tube, the thickness can be very precise for high guiding performance.

The compound used for these guides is a cotton fabric bound with thermosetting phenolic resin characterized by excellent heavy loads resistance, rigidity, hardness and high service temperature.

- Excellent resistance to heavy loads
- High precision of guiding
- Good resistance to “diesel effect”
- Extended service life
- Dimension suitable for both rod and piston
- Simple design of groove and assembly
- Low friction
- Good mechanical stability at high temperature
- Easy installation without expensive auxiliaries

GRF

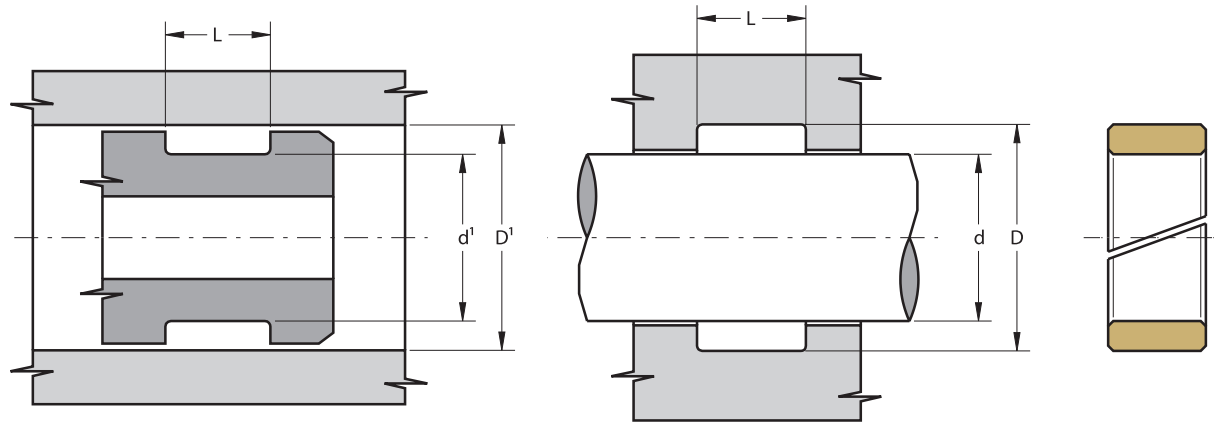

Part.	$d^{1\ h8}$ d_{f8}	$D^{1\ H9}$ D_{H8}	$L_{+0.2}$
GRF 20 25 9.7	20	25	9.7
GRF 25 30 9.7	25	30	9.7
GRF 27 32 9.7	27	32	9.7
GRF 30 35 9.7	30	35	9.7
GRF 35 40 9.7	35	40	9.7
GRF 36 41 9.7	36	41	9.7
GRF 36 41 15	36	41	15.0
GRF 37 42 9.7	37	42	9.7
GRF 40 45 9.7	40	45	9.7
GRF 45 50 9.7	45	50	9.7
GRF 50 55 9.7	50	55	9.7
GRF 50 55 15	50	55	15.0
GRF 55 60 9.7	55	60	9.7
GRF 55 60 15	55	60	15.0
GRF 56 61 9.7	56	61	9.7
GRF 58 63 9.7	58	63	9.7
GRF 58 63 15	58	63	15.0
GRF 60 65 9.7	60	65	9.7
GRF 60 65 15	60	65	15.0
GRF 63 68 9.7	63	68	9.7
GRF 65 70 9.7	65	70	9.7
GRF 65 70 15	65	70	15.0
GRF 70 75 9.7	70	75	9.7
GRF 70 75 15	70	75	15.0

Part.	$d^{1\ h8}$ d_{f8}	$D^{1\ H9}$ D_{H8}	$L_{+0.2}$
GRF 75 80 9.7	75	80	9.7
GRF 75 80 15	75	80	15.0
GRF 80 85 9.7	80	85	9.7
GRF 80 85 15	80	85	15.0
GRF 85 90 9.7	85	90	9.7
GRF 85 90 15	85	90	15.0
GRF 90 95 9.7	90	95	9.7
GRF 90 95 15	90	95	15.0
GRF 94 99 9.7	94	99	9.7
GRF 95 100 9.7	95	100	9.7
GRF 95 100 15	95	100	15.0
GRF 100 105 9.7	100	105	9.7
GRF 100 105 15	100	105	15.0
GRF 105 110 9.7	105	110	9.7
GRF 105 110 15	105	110	15.0
GRF 110 115 9.7	110	115	9.7
GRF 110 115 15	110	115	15.0
GRF 115 120 9.7	115	120	9.7
GRF 115 120 15	115	120	15.0
GRF 120 125 9.7	120	125	9.7
GRF 120 125 15	120	125	15.0
GRF 125 130 9.7	125	130	9.7
GRF 125 130 15	125	130	15.0
GRF 130 135 9.7	130	135	9.7

Part.	$d^{1\ h8}$ d_{f8}	$D^{1\ H9}$ D_{H8}	$L_{+0.2}$
GRF 130 135 15	130	135	15.0
GRF 135 140 9.7	135	140	9.7
GRF 135 140 15	135	140	15.0
GRF 140 145 9.7	140	145	9.7
GRF 140 145 15	140	145	15.0
GRF 145 150 9.7	145	150	9.7
GRF 145 150 15	145	150	15.0
GRF 150 155 9.7	150	155	9.7
GRF 150 155 15	150	155	15.0
GRF 155 160 9.7	155	160	9.7
GRF 155 160 15	155	160	15.0
GRF 160 165 9.7	160	165	9.7
GRF 160 165 15	160	165	15.0
GRF 165 170 15	165	170	15.0
GRF 170 175 9.7	170	175	9.7
GRF 170 175 15	170	175	15.0
GRF 175 180 9.7	175	180	9.7
GRF 175 180 15	175	180	15.0
GRF 180 185 9.7	180	185	9.7
GRF 180 185 15	180	185	15.0
GRF 185 190 9.7	185	190	9.7
GRF 185 190 15	185	190	15.0
GRF 190 195 15	190	195	15.0
GRF 195 200 9.7	195	200	9.7

GRF

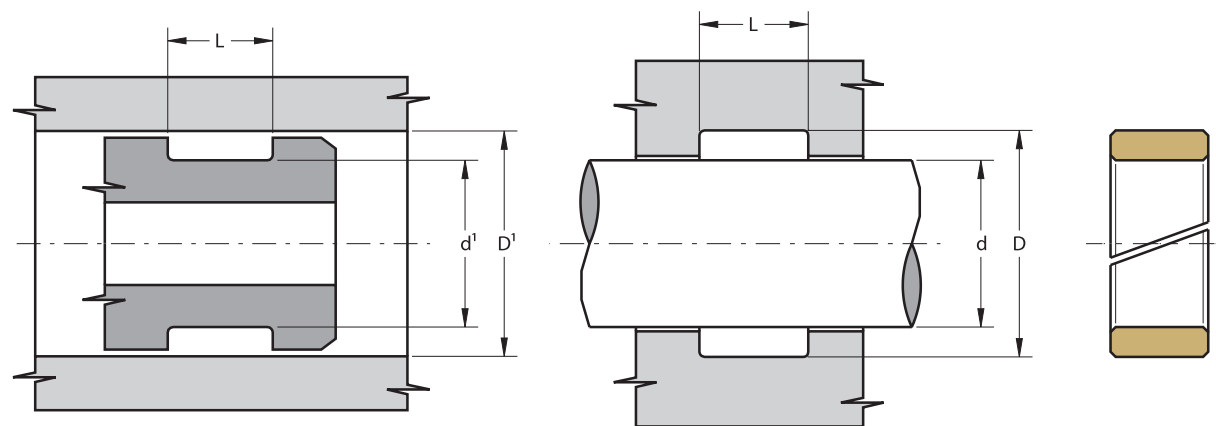

Part.	d'_{h8} d_{f8}	D'_{H9} D_{H8}	$L_{+0.2}$
GRF 195 200 15	195	200	15.0
GRF 200 205 15	200	205	15.0
GRF 240 245 15	240	245	15.0
GRF 255 260 15	255	260	15.0