

ADA

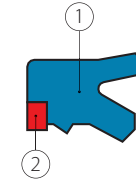

ADA

MATERIAL



① Type	Polyurethane
Designation	SEALPUR 93
Hardness	93 °ShA
② Type	Acetal resin
Designation	BEARITE

FIELD OF APPLICATION

Pressure ≤ 700 bar	
Speed ≤ 0.5 m/s	
Temperature -40°C ÷ +100°C	
Fluids	Hydraulic oils (mineral oil based) For other fluids contact our technical department

SURFACE ROUGHNESS

Dynamic surface	Ra ≤ 0.3 µm	Rt ≤ 2.5 µm
Static surface	Ra ≤ 1.6 µm	Rt ≤ 6.3 µm

GAP DIMENSION "g"

The largest gap dimension appearing in operation on the non-pressurised side:

200 bar	0.80 mm	500 bar	0.40 mm
300 bar	0.65 mm	600 bar	0.33 mm
400 bar	0.50 mm	700 bar	0.25 mm

LEAD-IN CHAMFERS

d	Smin
less 100	5 mm
100÷200	7 mm
over 200	10 mm

To avoid damaging the sealing lips during installation, housing must have rounded chamfers. Sharp edges and burrs within the installation area of the seal must be removed.

The above data are maximum values, they may be maintained for short periods and can not be used at the same time simultaneously.

This seal is mainly used with high pressure and the backup ring offsets large gaps without extrusion.

The asymmetric lips are designed to differentiate the behaviour of the lips on the static and dynamic surfaces: the static lip is flexible and more sensitive to pressure fluctuations; the dynamic lip is shorter and stronger to concentrate load against the dynamic surface.

Wear and dry run are largely prevented by additional lubricant retained within the gap created by the secondary lip. In some cases this second sealing lip may even act as a substitute for a costly tandem sealing system when complete sealing under certain working conditions can only be achieved by two seals placed one behind the other in separate

housing.

The material used to produce this seal is a polyurethane compound that ensures excellent properties on wear-resistance, extended service life and resistance against extrusion.

- Very high resistance against extrusion (backup ring)
- Extended service life
- Excellent wear-resistance
- Good temperature resistance
- Insensitive to structural deflections
- Easy installation without expensive auxiliaries

ADA

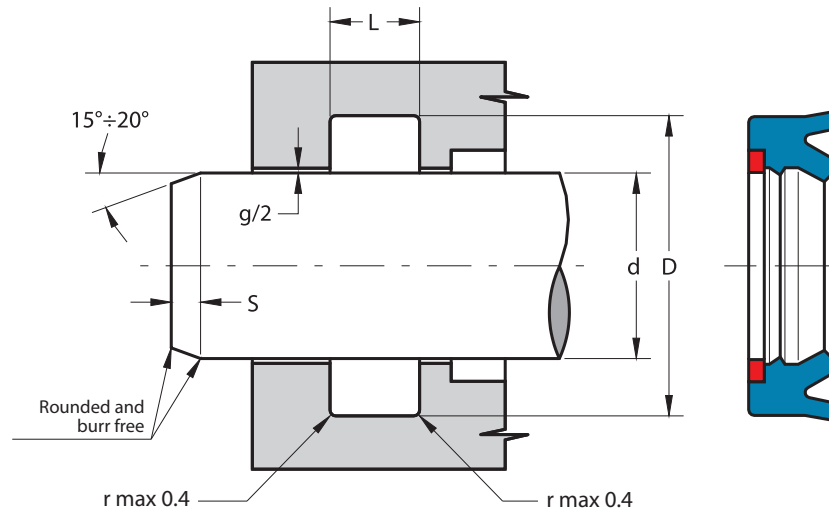

Part.	d ^{f7}	D ^{H10}	L ^{+0.25}
ADA 40 55 11.5	40	55.0	12.5
ADA 60 68 13	60	68.0	14.0
ADA 75 90 10	75	90.0	11.0
ADA 78 86 13	78	86.0	14.0
ADA 80 95 11.5	80	95.0	12.5
ADA 90 105 11.5	90	105.0	12.5
ADA 90 105 12	90	105.0	13.0
ADA 97 105 13	97	105.0	14.0
ADA 105 125 14.5	105	125.0	15.5
ADA 110 130 15	110	130.0	16.0
ADA 115 140 15	115	140.0	16.0
ADA 118 126 13	118	126.0	14.0
ADA 143 151 13	143	151.0	14.0
ADA 180 195 14	180	195.0	15.0