

A



**MATERIAL**



<b>Type</b>	<b>Designation</b>	<b>Hardness</b>
Polyurethane	SEALPUR 93	93 °ShA

**FIELD OF APPLICATION**

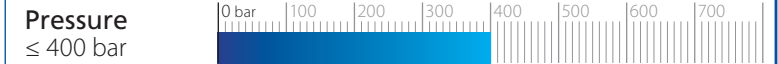

**Fluids** Hydraulic oils (mineral oil based)  
For other fluids contact our technical department

**SURFACE ROUGHNESS**

<b>Dynamic surface</b>	Ra ≤ 0.3 µm	Rt ≤ 2.5 µm
<b>Static surface</b>	Ra ≤ 1.6 µm	Rt ≤ 6.3 µm

**GAP DIMENSION "g"**

The largest gap dimension appearing in operation on the non-pressurised side:

50 bar	1.20 mm	300 bar	0.25 mm
100 bar	0.80 mm	400 bar	0.17 mm
200 bar	0.40 mm		

**LEAD-IN CHAMFERS**

d	Smin
less 100	5 mm
100÷200	7 mm
over 200	10 mm

To avoid damaging the sealing lips during installation, housing must have rounded chamfers. Sharp edges and burrs within the installation area of the seal must be removed.

The above data are maximum values, they may be maintained for short periods and can not be used at the same time simultaneously.

The rod seal type Aston Seals A assures a good reaction against shock pressure peaks and low friction in the low pressure range.

The asymmetric lips are designed to differentiate the behaviour of the lips on the static and dynamic surfaces: the static lip is flexible and more sensitive to pressure fluctuations; the dynamic lip is shorter and stronger to concentrate load against the dynamic surface.

The material used to produce this seal is a polyurethane compound that ensures excellent properties on wear-resistance, extended service life and resistance against extrusion.

- Extended service life
- High resistance against extrusion
- Excellent wear-resistance
- Good temperature resistance
- Insensitive to structural deflections
- Easy installation without expensive auxiliaries

A

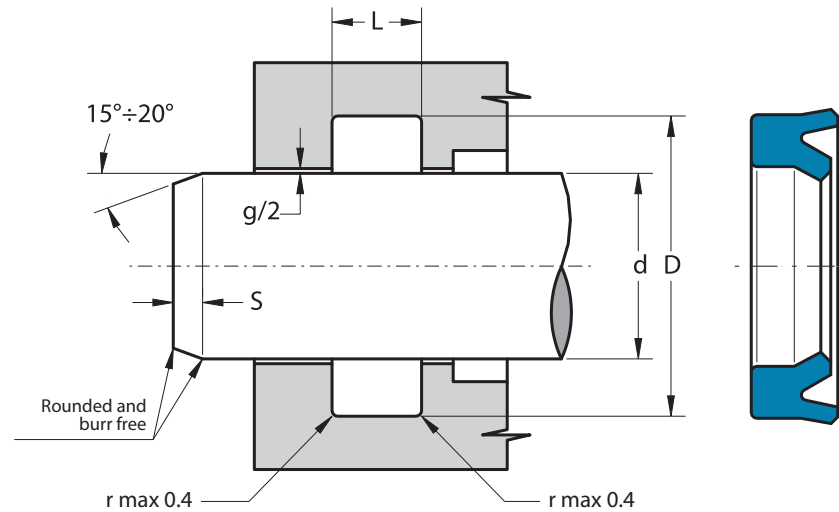

Part.	d <sup>f7</sup>	D <sup>H10</sup>	L <sup>+0.25</sup>
A 4 8 3	4	8.0	3.5
A 6 11 4	6	11.0	4.5
A 6 11 5.5	6	11.0	6.0
A 8 16 5.8	8	16.0	6.3
A 10 18 5.8	10	18.0	6.3
A 10 20 7	10	20.0	8.0
A 11 17 4.5	11	17.0	5.0
A 12 17 3.5	12	17.0	4.0
A 12 20 5.8	12	20.0	6.3
A 12 22 7	12	22.0	8.0
A 14 22 5.8	14	22.0	6.3
A 15 21 5	15	21.0	5.5
A 15 23 5.8	15	23.0	6.3
A 16 20.6 3.3	16	20.6	3.6
A 16 22 5	16	22.0	5.5
A 16 24 5.8	16	24.0	6.3
A 18 24 4.7	18	24.0	5.2
A 18 25 5	18	25.0	5.5
A 18 26 5	18	26.0	5.5
A 18 26 5.8	18	26.0	6.3
A 18 28 7	18	28.0	8.0
A 18 28 8	18	28.0	9.0
A 20 26 5	20	26.0	5.5
A 20 28 5.8	20	28.0	6.3

Part.	d <sup>f7</sup>	D <sup>H10</sup>	L <sup>+0.25</sup>
A 20 28 6	20	28.0	7.0
A 20 28 7	20	28.0	8.0
A 20 30 7	20	30.0	8.0
A 22 30 5	22	30.0	5.5
A 22 30 5.8	22	30.0	6.3
A 22 32 7	22	32.0	8.0
A 24 30 4.5	24	30.0	5.0
A 25 32 6	25	32.0	7.0
A 25 33 5	25	33.0	5.5
A 25 33 5.8	25	33.0	6.3
A 25 33 6	25	33.0	7.0
A 25 33 6.3	25	33.0	7.0
A 25 33 7	25	33.0	8.0
A 25 35 6	25	35.0	7.0
A 25 35 7	25	35.0	8.0
A 25 35 8	25	35.0	9.0
A 25 40 10	25	40.0	11.0
A 27 35 5.8	27	35.0	6.3
A 28 36 5.8	28	36.0	6.3
A 28 38 7	28	38.0	8.0
A 28 40 8.5	28	40.0	9.5
A 30 38 5.8	30	38.0	6.3
A 30 38 8	30	38.0	9.0
A 30 40 5.8	30	40.0	6.3

Part.	d <sup>f7</sup>	D <sup>H10</sup>	L <sup>+0.25</sup>
A 30 40 7	30	40.0	8.0
A 30 40 9.5	30	40.0	10.5
A 30 43 9	30	43.0	10.0
A 32 37 2.6	32	37.0	3.0
A 32 40 5.8	32	40.0	6.3
A 32 40 8	32	40.0	9.0
A 32 42 7	32	42.0	8.0
A 32 42 10	32	42.0	11.0
A 32 45 10	32	45.0	11.0
A 32 47 10	32	47.0	11.0
A 32 48 10	32	48.0	11.0
A 33 43 10	33	43.0	11.0
A 34 41 5	34	41.0	5.5
A 35 42 4.6	35	42.0	5.1
A 35 43 5.8	35	43.0	6.3
A 35 43 8	35	43.0	9.0
A 35 45 7	35	45.0	8.0
A 35 45 10	35	45.0	11.0
A 35 46 8	35	46.0	9.0
A 36 44 5.8	36	44.0	6.3
A 36 44 8	36	44.0	9.0
A 36 46 6	36	46.0	7.0
A 36 46 7	36	46.0	8.0
A 36 46 10	36	46.0	11.0

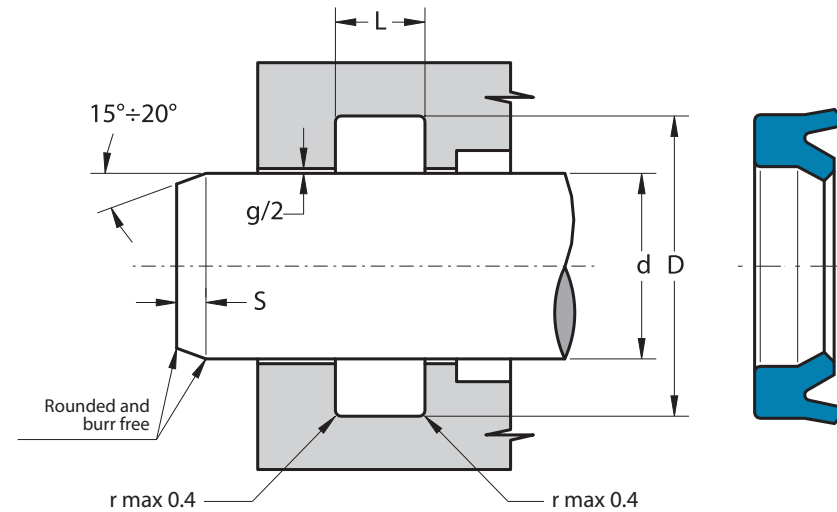

Part.	d <sup>f7</sup>	D <sup>H10</sup>	L <sup>+0.25</sup>
A 36 48 8	36	48.0	9.0
A 36 48 11	36	48.0	12.0
A 37 47 7	37	47.0	8.0
A 38 44.5 4.7	38	44.5	5.3
A 38 45 5	38	45.0	5.5
A 39 50 10	39	50.0	11.0
A 40 48 4	40	48.0	4.5
A 40 48 5.8	40	48.0	6.3
A 40 48 8	40	48.0	9.0
A 40 50 7	40	50.0	8.0
A 40 50 10	40	50.0	11.0
A 40 52 8	40	52.0	9.0
A 40 55 10	40	55.0	11.0
A 40 60 10	40	60.0	11.0
A 42 47 2.6	42	47.0	3.0
A 42 50 5.8	42	50.0	6.3
A 42 50 6	42	50.0	7.0
A 45 53 5.8	45	53.0	6.3
A 45 53 8	45	53.0	9.0
A 45 55 7	45	55.0	8.0
A 45 55 10	45	55.0	11.0
A 45 58 9	45	58.0	10.0
A 45 60 10	45	60.0	11.0
A 45 60 11.5	45	60.0	12.5

Part.	d <sup>f7</sup>	D <sup>H10</sup>	L <sup>+0.25</sup>
A 46 56 7	46	56.0	8.0
A 50 58 8	50	58.0	9.0
A 50 60 7	50	60.0	8.0
A 50 60 10	50	60.0	11.0
A 50 63 10	50	63.0	11.0
A 50 65 10	50	65.0	11.0
A 50 65 11.5	50	65.0	12.5
A 50 68 9	50	68.0	10.0
A 55 63 7	55	63.0	8.0
A 55 65 10	55	65.0	11.0
A 55 65 12	55	65.0	13.0
A 55 65 7	55	65.0	8.0
A 55 70 9.5	55	70.0	10.5
A 56 66 7	56	66.0	8.0
A 56 66 10	56	66.0	11.0
A 56 68 7	56	68.0	8.0
A 56 71 10	56	71.0	11.0
A 56 71 11.5	56	71.0	12.5
A 60 65.6 5.6	60	65.6	6.3
A 60 68 8	60	68.0	9.0
A 60 70 7	60	70.0	8.0
A 60 70 10	60	70.0	11.0
A 60 70 12	60	70.0	13.0
A 60 72 8	60	72.0	9.0

Part.	d <sup>f7</sup>	D <sup>H10</sup>	L <sup>+0.25</sup>
A 60 72 9	60	72.0	10.0
A 60 73 10	60	73.0	11.0
A 63 75 8.6	63	75.0	9.6
A 60 75 10	60	75.0	11.0
A 60 75 12	60	75.0	13.0
A 63 73 10	63	73.0	11.0
A 63 78 10	63	78.0	11.0
A 63 78 11.5	63	78.0	12.5
A 65 78 10	65	78.0	11.0
A 65 80 10	65	80.0	11.0
A 65 80 12	65	80.0	13.0
A 70 80 7	70	80.0	8.0
A 70 80 10	70	80.0	11.0
A 70 80 12	70	80.0	13.0
A 70 82 8.6	70	82.0	9.6
A 70 83 10	70	83.0	11.0
A 70 85 10	70	85.0	11.0
A 70 85 11	70	85.0	12.0
A 70 85 12	70	85.0	13.0
A 73 82.5 7	73	82.5	8.0
A 75 85 10	75	85.0	11.0
A 75 88 10	75	88.0	11.0
A 75 90 10	75	90.0	11.0
A 80 90 7	80	90.0	8.0

A

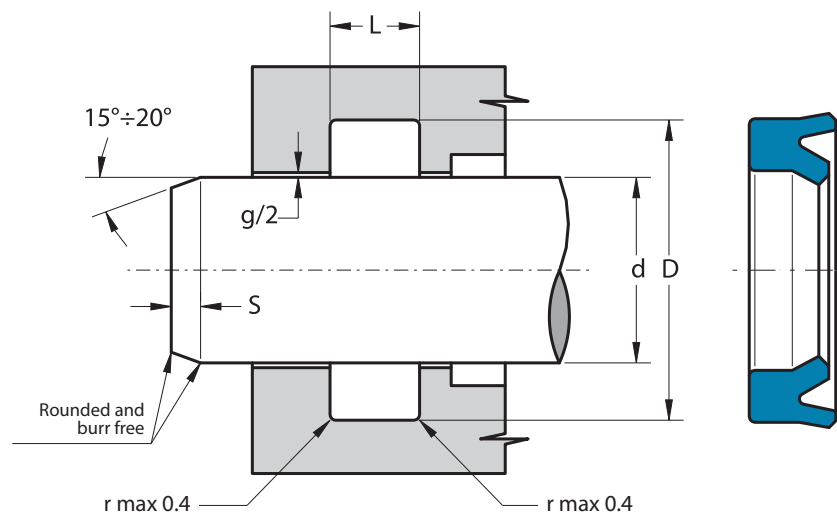

Part.	d <sup>f7</sup>	D <sup>H10</sup>	L <sup>+0.25</sup>
A 80 90 12	80	90.0	13.0
A 80 92 8.6	80	92.0	9.6
A 80 93 10	80	93.0	11.0
A 80 95 10	80	95.0	11.0
A 80 95 11.5	80	95.0	12.5
A 80 100 12	80	100.0	13.0
A 85 95 7.2	85	95.0	8.2
A 85 100 12	85	100.0	13.0
A 90 100 12	90	100.0	13.0
A 90 102 8.6	90	102.0	9.6
A 90 105 10	90	105.0	11.0
A 90 105 11.5	90	105.0	12.5
A 90 105 12	90	105.0	13.0
A 90 110 12	90	110.0	13.0
A 95 105 5	95	105.0	5.7
A 100 108 5	100	108.0	5.5
A 100 109.3 5.7	100	109.3	6.2
A 100 111 4	100	111.0	4.5
A 100 115 9	100	115.0	10.0

Part.	d <sup>f7</sup>	D <sup>H10</sup>	L <sup>+0.25</sup>
A 100 115 10.5	100	115.0	11.5
A 100 115 12	100	115.0	13.0
A 100 120 12	100	120.0	13.0
A 100 120 12.5	100	120.0	13.5
A 100 120 15	100	120.0	16.0
A 105 113 5	105	113.0	5.5
A 105 115 5.7	105	115.0	6.2
A 110 120 5.5	110	120.0	6.0
A 110 120 12	110	120.0	13.0
A 110 125 9.6	110	125.0	10.6
A 110 130 12	110	130.0	13.0
A 115 130 11	115	130.0	12.0
A 120 128 5	120	128.0	5.5
A 120 140 15	120	140.0	16.0
A 125 145 12	125	145.0	13.0
A 130 138 5	130	138.0	5.5
A 130 145 14	130	145.0	15.0
A 140 150 6	140	150.0	7.0
A 140 150 11.5	140	150.0	12.5

Part.	d <sup>f7</sup>	D <sup>H10</sup>	L <sup>+0.25</sup>
A 155 165 6	155	165.0	7.0
A 160 185 19	160	185.0	20.0
A 165 175 6	165	175.0	7.0
A 180 200 14.5	180	200.0	15.5
A 200 210 6	200	210.0	7.0
A 200 220 14.5	200	220.0	15.5
A 216 226 6	216	226.0	7.0
A 238 258 15	238	258.0	16.0
A 239.5 260.5 16.5	239.5	260.5	17.5
A 240 260 15	240	260.0	16.0
A 265 295 19	265	295.0	20.0

Inch sizes

A 1375 1875 0375	34.92	47.62	10.5
A 2000 2375 0315	50.8	60.32	8.7
A 7000 8000 0765	177.8	203.2	20.4