

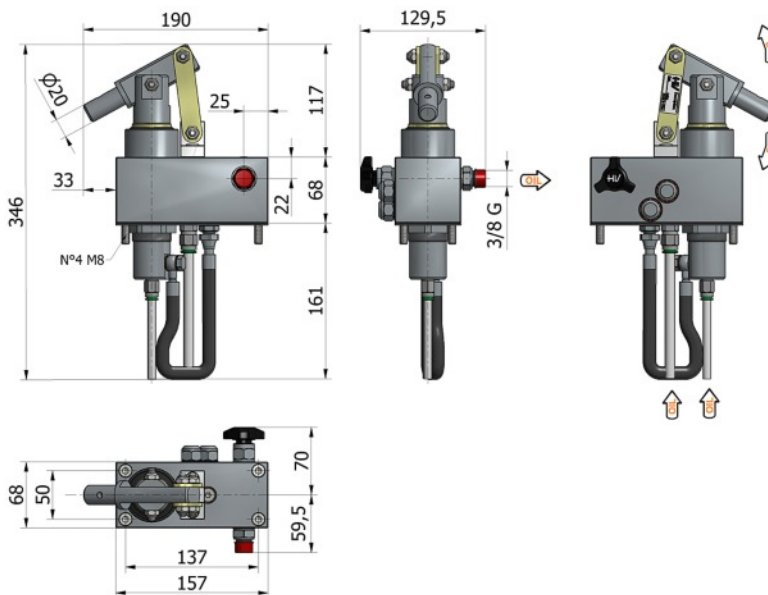

# PM2V 5-50 a-byB

with release hand knob  
 with automatic control for the 1st speed  
 with pressure relief valve and pressure-gauge  
 two speed hand pump for a single acting cylinder  
 for fixing to tank

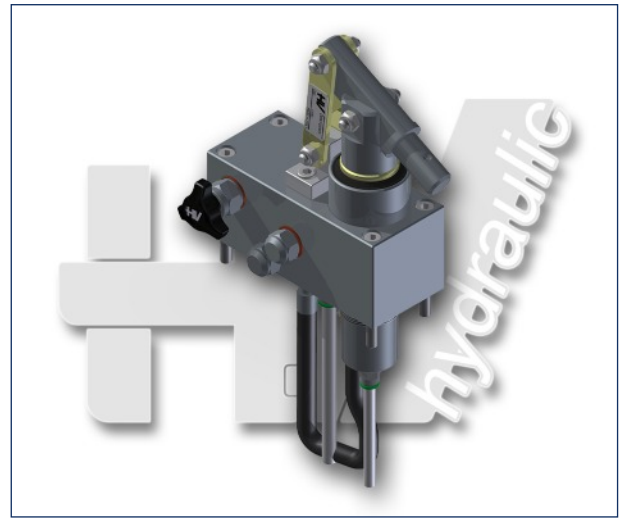
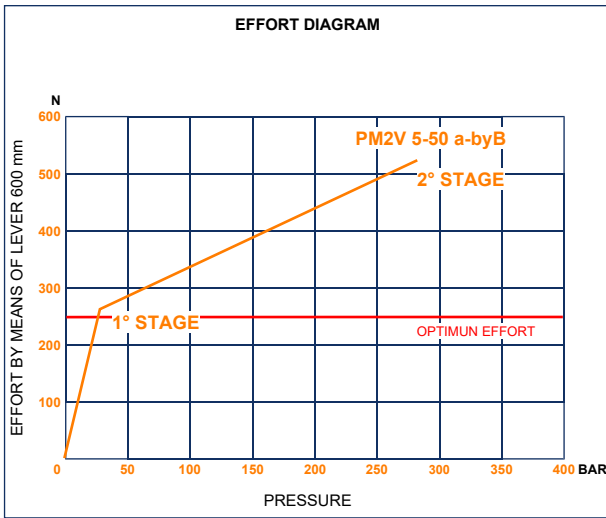
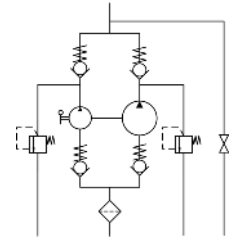

- Specifications:**
- Yellow zinc plating + sealant 15 micron external parts
  - Piston treated with Niploy
  - Lever connection Ø 20
  - Pressure relief valve standard setting: 280 bar
  - Oil tank mounting kit included

DISPLACEMENT cm <sup>3</sup>	A mm	B mm	C mm	D °	E °	DISPLACEMENT cm <sup>3</sup>		PRESSURE BAR		MASS KG	CODE WITHOUT BELLOWS	CODE WITH BELLOWS
						STAGE 1	STAGE 2	STAGE 1	STAGE 2			
5-50	--	--	--	29	27	50,200	5,300	30	280	7,776	6070.6000	--